

2023

# HUMAN

PRODUCT CATALOG



VITROSENS







**2023 HUMAN PRODUCT CATALOG**

# About Us



Vitrosens Biotechnology is a high-tech establishment in Turkey that incorporates R&D, production, and sales with the aim of providing and developing accurate, game-changing in vitro diagnostic tools. With our rapidly growing manufacturing center, comprehensive Quality Management System, and robust R & D team of experts, we are dedicated to providing high-quality, innovative, convenient, and reliable lateral flow immunoassays, fluorescence immunoassays (FIA), and molecular diagnosis (PCR) kits for human diagnosis. Moreover, with our well-developed lateral flow cassette OEM (Original Equipment Manufacturer), ODM (Original Design Manufacturer), and private labeling services, we aim to help medical device distributors commercialize the most customized IVD products.

## TimeLine

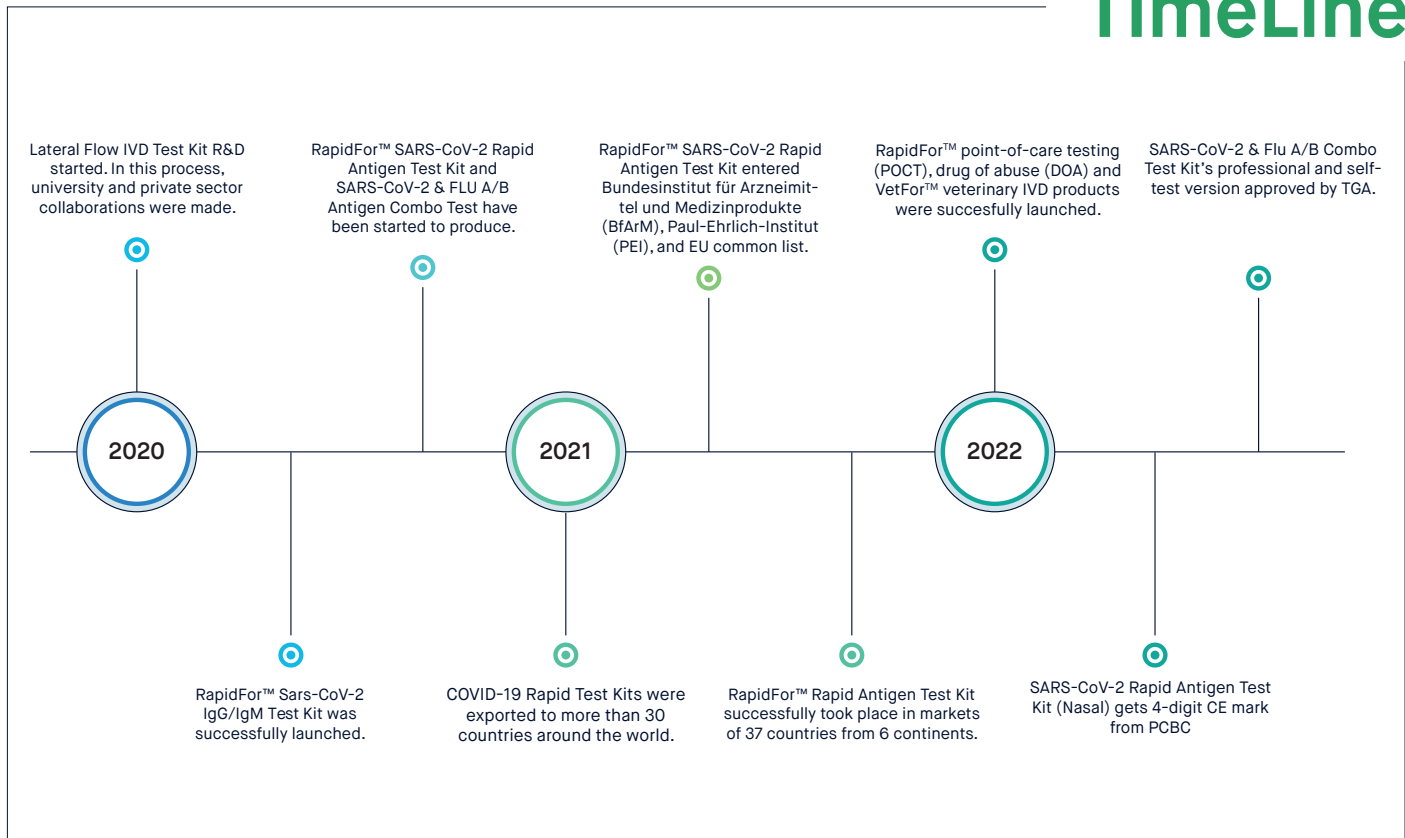

# Contents

## SEXUALLY TRANSMITTED DISEASES RAPID TEST

- 08 **HIV Ag/Ab Combo** Rapid Test Kit
- 08 **HIV 1/2 & Syphilis** Combo Tri-line Rapid Test Kit
- 09 **Anti-Syphilis** Rapid Test Kit
- 09 **HBsAg** Rapid Test Kit
- 10 **Anti-HCV** Rapid Test Kit
- 10 **Anti-HBs** Rapid Test Kit
- 11 **Anti-HIV (1/2)** Rapid Test Kit

## RESPIRATORY DISEASES RAPID TEST

- 12 **SARS-CoV-2** Rapid Antigen Test Kit (Nasal)
- 12 **SARS-CoV-2 & FLU A/B** Antigen Combo Test
- 13 **SARS-CoV-2 IgG/IgM** Test
- 13 **Influenza A/B** Rapid Test Kit
- 14 **RSV** Rapid Test Kit
- 14 **SARS-CoV-2 & FLU A/B** Rapid Test Kit
- 15 **Strep A** Rapid Test Kit
- 15 **SARS-CoV-2 & FLU A/B & RSV** Combo Rapid Test Kit
- 16 **FLU A/B & RSV** Combo Test Kit
- 16 **FLU A/B & RSV & ADV** Combo Test Kit
- 17 **SARS-CoV-2 & Flu A/B & RSV & ADV** Combo Test Kit

## GASTROINTESTINAL DISEASES RAPID TEST

- 18 **Rota-Adeno Tri-Line** Rapid Test
- 18 **H.Pylori Ag** Rapid Test Kit
- 19 **Norovirus** Rapid Test Kit

## TROPICAL DISEASES RAPID TEST

- 20 **Malaria P.F/Pan** Rapid Test Kit
- 20 **Malaria P.F/P.V** Rapid Test Kit
- 21 **Dengue IgG/IgM & NS1 Ag** Combo Rapid Test Kit

## TUMOR MARKERS RAPID TEST

- 22 **FOB** Rapid Test Kit
- 22 **PSA** Rapid Test Kit
- 23 **AFP** Rapid Test Kit

## FERTILITY RAPID TEST

- 24 **hCG** Rapid Test Kit
- 25 **Ovulation LH** Rapid Test Kit

## OTHERS RAPID TEST

- 26 **Toxo IgG/IgM** Rapid Test Kit
- 26 **Troponin I** Rapid Test Kit
- 27 **Rubella IgG/IgM** Rapid Test Kit

## DRUG OF ABUSE

- 28 **Saliva Multi-Drug** Test Cup
- 29 **Urine Multi Drug** Test Cup
- 30 **Cotinine (COT)** Rapid Test Kit

## MOLECULAR DIAGNOSTIC

- 31 **SARS-CoV-2 Detection RT-qPCR** Kit
- 31 **SARS-CoV-2 & FLU A/B Detection RT-qPCR** Kit
- 32 **Viral Nucleic Acid Purification** Kit
- 32 **Genomic DNA Purification Kit From Blood**
- 33 **Viral Transport Medium**
- 33 **Viral Nucleic Acid Transport Medium**

## ORDER INFORMATION

Category	Ref. No	Name	Specimen*	Kit Size	Certificates
SEXUALLY	VMD02	Anti-HBs Rapid Test Kit	S/P/WB	25T	ISO
	VMD03	Anti-HCV Rapid Test Kit	S/P/WB	25T	ISO
	VMD04	Anti-Syphilis Rapid Test Kit	S/P/WB	25T	CE
	VMD10	HBsAg Rapid Test Kit	S/P/WB	25T	ISO
	VMD14	HIV Ag/Ab Combo Rapid Test Kit	S/P/WB	25T	ISO
	VMD32	HIV 1/2 & Syphilis Combo Tri-line Rapid Test Kit	S/P/WB	25T	ISO
RESPIRATORY	VSCD02ST	SARS-CoV-2 Rapid Antigen Test (Nasal)	N	1/2/5T	CE 1434
	VSCD10	SARS-CoV-2 & FLU A/B Antigen Combo Test	N/NP	25T	TGA
	VSCD10ST	SARS-CoV-2 & FLU A/B Antigen Combo Test (Nasal)	N	1/2/5T	TGA
	VSCD01	SARS-CoV-2 IgG/IgM Test	S/P/WB	25T	CE
	VMD17	Influenza A/B Rapid Test Kit	N/NP	25T	CE
	VMD66	RSV Rapid Test Kit	NP	25T	CE
	VSCD08	SARS-CoV-2 & FLU A/B Rapid Antigen Test	N/NP	25T	CE
	VSCD02	SARS-CoV-2 Rapid Antigen Test	N/NP/OP	25	CE
	VMD36	Strep A Rapid Test Kit	OP	25T	CE
	VMD71	SARS-CoV-2 & FLU A/B & RSV Combo Rapid Test Kit	N/NP	25T	CE
	VMD77	FLU A/B & RSV Combo Test Kit	NP	25T	CE
	VMD78	FLU A/B & RSV & ADV Combo Test Kit	NP	25T	CE
	VMD79	SARS-CoV-2 & Flu A/B & RSV & ADV Combo Test Kit	NP	25T	CE
GASTROINTESTINAL	VMD75	Rota-Adeno Tri-Line Test Kit	F	20T	CE
	VMD16	H.Pylori Ag Rapid Test Kit	F	20T	CE
	VMD24	Rotavirus Rapid Test Kit	F	20T	CE
	VMD35	H.Pylori Ab Rapid Test Kit	F	25T	CE
	VMD40	Adenovirus Rapid Test Kit	F	20T	CE
	VMD41	Norovirus Rapid Test Kit	F	20T	CE
TROPICAL	VMD06	Dengue IgG/IgM & NS1 Combo Rapid Test Kit	S/P/WB	25T	CE
	VMD08	Dengue NS1 Ag Rapid Test Kit	S/P/WB	25T	CE
	VMD20	Malaria P.F Rapid Test Kit	WB	25T	CE
	VMD21	Malaria P.F/Pan Rapid Test Kit	WB	25T	CE
	VMD22	Malaria P.F/P.V Rapid Test Kit	WB	25T	CE
	VMD29	Typhoid IgG/IgM Rapid Test Kit	S/P/WB	25T	CE
	VMD38	Dengue IgG/IgM Rapid Test Kit	S/P/WB	25T	CE

\* S: Serum, P: Plasma, WB: Whole Blood, F: Feces, NP: Nasopharyngeal Swab, OP: Oropharyngeal Swab, N: Nasal Swab

Category	Ref. No	Name	Specimen*	Kit Size	Certificates
TUMOR MARKERS	VMD09	FOB Rapid Test Kit	F	20T	CE
	VMD46	PSA Rapid Test Kit	S/P/WB	25T	CE
	VMD44	AFP Rapid Test Kit	S/P/WB	25T	CE
	VMD45	CEA Rapid Test Kit	S/P/WB	25T	CE
FERTILITY	VMD61	Ovulation LH Rapid Test Kit	U	25T	CE
	VMD59	hCG Rapid Test Kit	U	25/50/100T	CE
OTHERS	VMD28	Toxo IgG/IgM Rapid Test Kit	S/P/WB	25T	CE
	VMD49	Troponin I Rapid Test Kit	S/P/WB	25T	CE
	VMD26	Rubella IgG/IgM Rapid Test Kit	S/P/WB	25T	CE
DOA	VDDOA01	Saliva Multi-Drug Test Cup	SL	25/50T	CE
	VDDOA02	Urine Multi-Drug Test Cup	U	10/50T	CE
	VDDOA13	Continine (COT) Rapid Test kit	U	25T	CE

\* S: Serum, P: Plasma, WB: Whole Blood, F: Feces, U: Urine, SL: Saliva

Category	Ref. No	Name	Storage	Kit Size	Certificates
MOLECULAR DIAGNOSTIC	CFP01	SARS-CoV-2 Detection RT-qPCR Kit	-25°C~ -15°C	100R	CE
	CFP02	HPV qPCR Kit	-25°C~ -15°C	100R	CE
	CFP03	HCV qPCR Kit	-25°C~ -15°C	100R	CE
	CFP04	HIV-1 qPCR Kit	-25°C~ -15°C	100R	CE
	CFP05	SARS-CoV-2 & Flu A/B Detection RT-qPCR Kit	-25°C~ -15°C	100R	CE
	CFP06	SARS-CoV-2 & Flu & RSV Detection RT-qPCR Kit	-25°C~ -15°C	100R	CE
	VIRA01	Viral Nucleic Acid Purification Kit	2°C~ 25°C	100R	CE
	VIRA02	Genomic DNA Purification Kit From Blood	2°C ~25°C	100R	CE
	VIRA03	Viral RNA Purification Kit	2°C ~25°C	100R	CE
	VTF01	Viral Transform Medium	2°C~ 25°C	100T	CE
	VNF01	Viral Nucleic Acid Transport Medium	2°C~ 25°C	100T	CE

# SEXUALLY TRANSMITTED DISEASES RAPID TEST

## HIV Ag/Ab Combo Rapid Test Kit

It is designed for the qualitative and differentiated detection of Human Immunodeficiency Virus (HIV) antigens and HIV specific antibodies in human serum, plasma, and whole blood samples.

### Advantages

- Convenient and cost-effective
- Screening for HIV antigens and antibodies
- Uses minimal sample volume
- Enables early diagnosis
- Easy to handle



For seeing the Interpretation follow [page 35 Interpretation I](#)

### Test Procedure



Ref. No	Target	Specimen	Kit Size	Certificates
VMD14	HIV Antigen & HIV Specific Antibody	S/P/WB	25T	ISO

## HIV 1/2 & Syphilis Combo Tri-line Rapid Test Kit

This device is intended for the *in vitro* qualitative detection and differentiation of antibodies against HIV-1/2 and treponema pallidum (TP) in serum, plasma, and whole blood samples.

### Advantages

- Simultaneously detects and differentiates syphilis and HIV
- Qualitative, easy-to-read results in 15 minutes
- Safe, quick, and convenient sample collection
- Ergonomic design for minimum risk of contamination
- Assists the initiation of treatment and the prevention of further transmission



For seeing the Interpretation follow [page 35 Interpretation J](#)

### Test Procedure

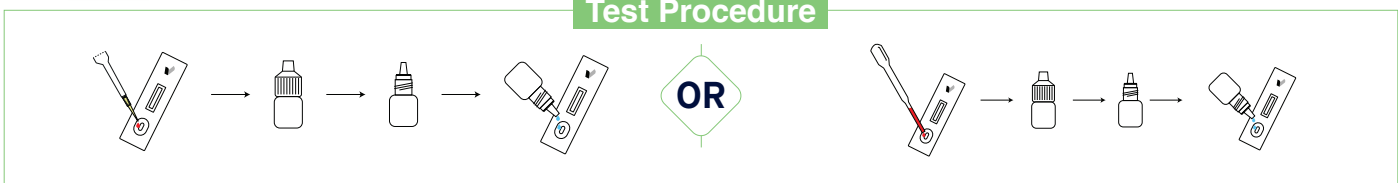

Ref. No	Target	Specimen	Kit Size	Certificates
VMD32	HIV 1/2 Antibody & Syphilis Specific Antibody	S/P/WB	25T	ISO



# Anti-Syphilis

## Rapid Test kit

Test kit is a simple point-of-care test enabling qualitative syphilis screening in human serum, plasma, and whole blood samples.

### Advantages

- Facilitates early detection and immediate treatment
- Prevents transmitting the infection
- Hinders the emergence of long-term complications and unfavorable outcomes of pregnancy
- Easy sampling, simple procedure
- Easily readable results



For seeing the Interpretation follow [page 34 Interpretation A](#)

### Test Procedure

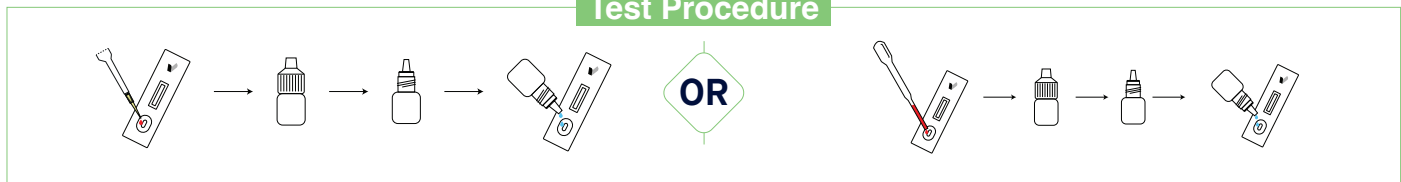

Ref. No	Target	Specimen	Kit Size	Certificates
VMD04	Syphilis Specific Antibody	S/P/WB	25T	CE

# HBsAg

## Rapid Test Kit

Test kit is intended for the qualitative detection of Hepatitis B surface antigens (HBsAg) in human serum, plasma, and whole blood samples.



For seeing the Interpretation follow [page 34 Interpretation A](#)

### Advantages

- Accurate diagnosis of hepatitis B virus infection
- Simplified sampling and procedure
- Provides visual, qualitative, and clear results
- Rapid, sensitive, and accurate results
- No need for analyzer to read

### Test Procedure

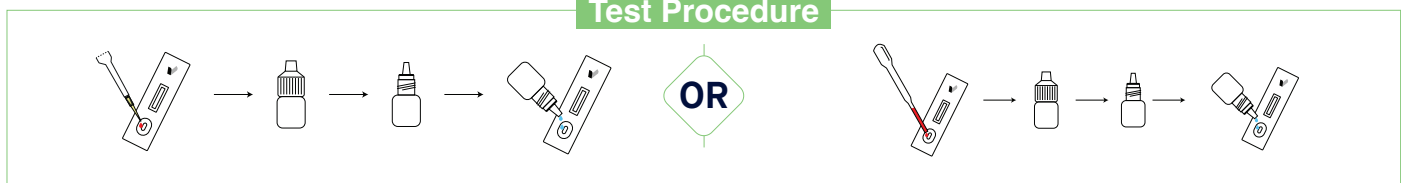

Ref. No	Target	Specimen	Kit Size	Certificates
VMD10	Hepatitis B Antigens	S/P/WB	25T	ISO

# SEXUALLY TRANSMITTED DISEASES RAPID TEST

## Anti-HCV Rapid Test Kit

Test kit is created for the qualitative determination of antibodies specific to Hepatitis C Virus (HCV) in human serum, plasma, and whole blood samples.

### Advantages

- Successful qualitative detection of both present and previous infections of HCV
- Accurately diagnoses both symptomatic and asymptomatic patients
- Visually displayed results
- Rapid and accurate results
- Simple sampling and procedure



For seeing the Interpretation follow [page 34 Interpretation A](#)

### Test Procedure

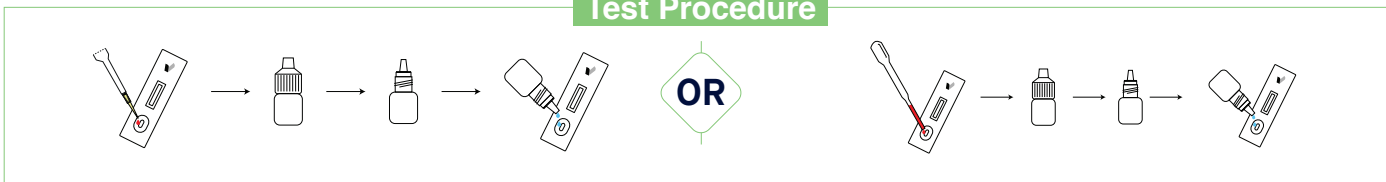

Ref. No	Target	Specimen	Kit Size	Certificates
VMD03	Hepatitis C Specific Antibody	S/P/WB	25T	ISO

## Anti-HBs Rapid Test Kit

It is designed for the qualitative determination of specific antibodies to Hepatitis B surface (HBs) in human serum, plasma, and whole blood samples.



### Advantages

- Fast screening
- Assisting the diagnosis of Hepatitis B
- Minimalistic design
- High rates of sensitivity, specificity, and overall accuracy
- Easy and safe procedure



For seeing the Interpretation follow [page 34 Interpretation A](#)

### Test Procedure

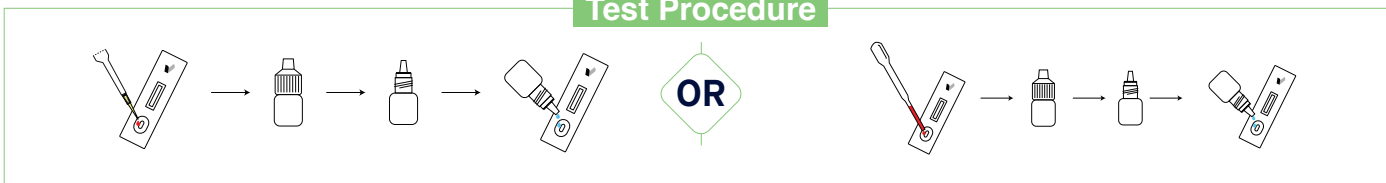

Ref. No	Target	Specimen	Kit Size	Certificates
VMD02	Hepatitis B Specific Antibody	S/P/WB	25T	ISO

# Anti-HIV (1/2)

## Rapid Test kit

Test kit qualitatively detects and differentiates Human Immunodeficiency Virus (HIV) specific antibodies in human serum, plasma, and whole blood samples.

### Advantages

- 2 in 1 test for effective screening for HIV type 1 and type 2 specific antibodies.
- Simple procedure
- Highly sensitive even in early infection stage
- High rates of sensitivity, specificity
- Safe method



For seeing the Interpretation follow [page 34 Interpretation A](#)

### Test Procedure

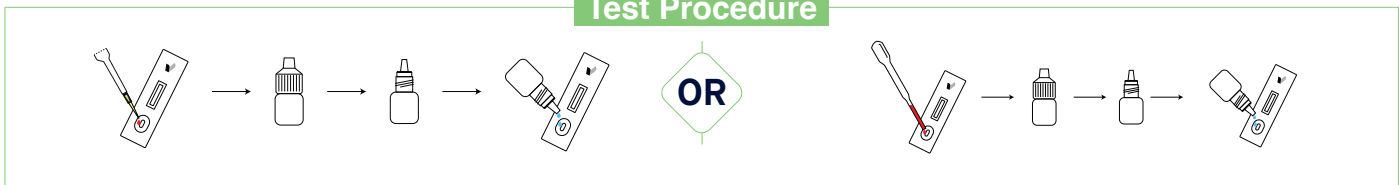

Ref. No	Target	Specimen	Kit Size	Certificates
VMD12	HIV (1/2) Specific Antibody	S/P/WB	25T	ISO

### Sample Collection

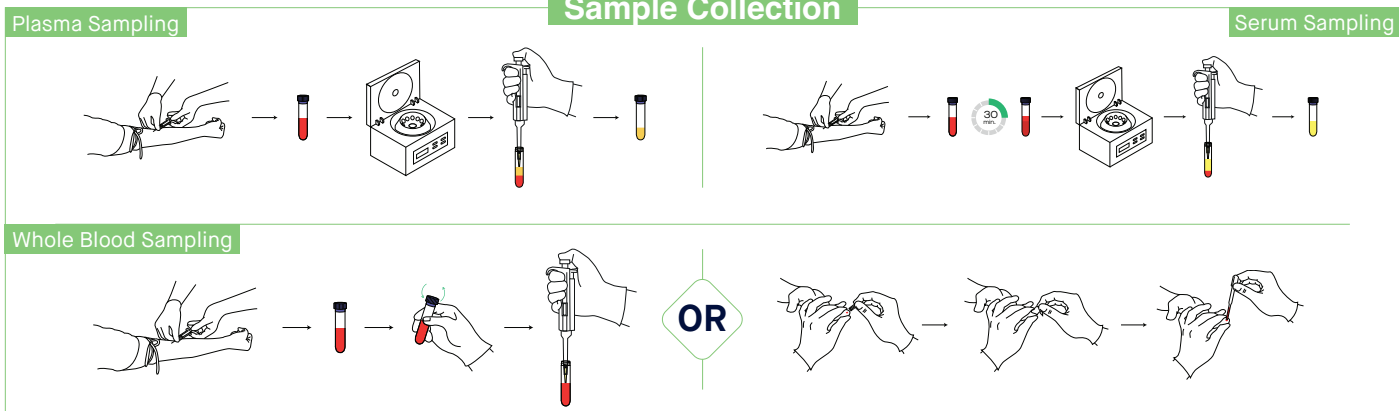

Ref. No	Name	Specimen	Kit Size	Certificates
VMD02	Anti-HBs Rapid Test Kit	S/P/WB	25T	ISO
VMD03	Anti-HCV Rapid Test Kit	S/P/WB	25T	ISO
VMD04	Anti-Syphilis Rapid Test Kit	S/P/WB	25T	CE
VMD10	HBsAg Rapid Test Kit	S/P/WB	25T	ISO
VMD14	HIV Ag/Ab Combo Rapid Test Kit	S/P/WB	25T	ISO
VMD32	HIV1/2 & Syphilis Combo Tri-line Rapid Test Kit	S/P/WB	25T	ISO

# RESPIRATORY DISEASES RAPID TEST

## SARS-CoV-2 Rapid Antigen Test (Nasal)

It is designed for qualitative detection of SARS-CoV-2 antigen in nasal swab samples at your home comfort.

### Advantages

- User friendly procedure
- Less-invasive
- Variant detection including Omicron
- Early phase detection
- Fast and accurate results



### Test Procedure



Ref. No	Target	Specimen	Kit Size	Certificates
VSCD02ST	SARS-CoV-2 Antigen	N	1/2/5T	CE 1434

## SARS-CoV-2 & FLU A/B Antigen Combo Test

It is designed for qualitative and differential diagnosis of SARS-CoV-2 and Influenza A/B antigens in nasal and nasopharyngeal swab samples.



### Advantages

- 2 in 1 test for both Flu A/B and SARS-CoV-2
- Easy procedure
- Variant detection including Omicron
- Early phase detection
- Safe and accurate results

For seeing the Interpretation follow page 35 Interpretation F

### Test Procedure



Ref. No	Target	Specimen	Kit Size	Certificates
VSCD10	SARS-CoV-2 & FLU A/B Antigen	N/NP	25T	TGA

# SARS-CoV-2 IgG/IgM

## Test

It is designed for qualitative detection IgG and IgM antibodies against SARS-CoV-2 in serum, plasma, and whole blood samples.

### Advantages

- 2 in 1 test for both IgG and IgM antibodies
- Simple and safe procedure
- Easy sampling by fingertip blood
- High sensitivity
- Accurate and rapid results



For seeing the Interpretation follow [page 34 Interpretation B](#)

### Test Procedure

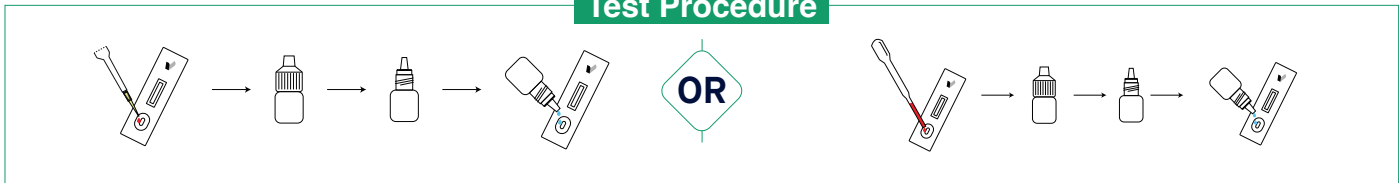

Ref. No	Target	Specimen	Kit Size	Certificates
VSCD01	SARS-CoV-2 Specific IgG/IgM Antibodies	S/P/WB	25T	CE

# Influenza A/B

## Rapid Test Kit

Test kit is a single test kit to identify both Influenza A and B viral nucleoprotein antigens in human nasopharyngeal and nasal swab samples.



### Advantages

- 2 in 1 test for both influenza A and B
- Uses nasopharyngeal swab
- Easy to perform
- Results available within 15 minutes
- Safe, efficient, and accurate methodology



For seeing the Interpretation follow [page 34 Interpretation C](#)

### Test Procedure

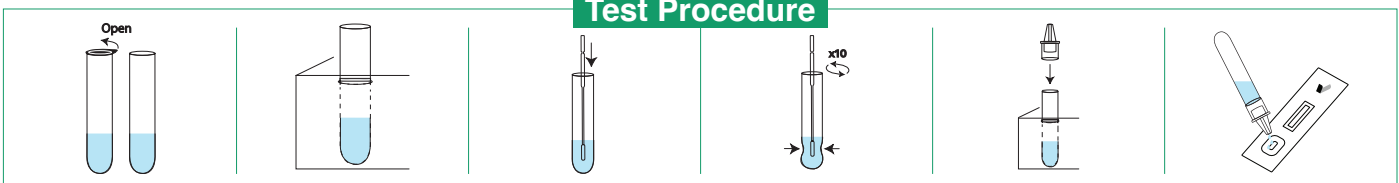

Ref. No	Target	Specimen	Kit Size	Certificates
VMD17	Influenza A/B Antigen	N/NP	25T	CE

# RESPIRATORY DISEASES RAPID TEST

## RSV

### Rapid Test Kit

Test kit is a lateral flow sandwich assay designed for *in vitro* qualitative detection of the nucleocapsid antigen of RSV in nasopharyngeal swab samples.

#### Advantages

- Usable for early diagnosis
- Simple sampling
- Safe and reliable performance
- Results available within 15 minutes
- High level of sensitivity and accuracy



For seeing the Interpretation follow [page 34 Interpretation A](#)

#### Test Procedure



Ref. No	Target	Specimen	Kit Size	Certificates
VMD66	RSV Antigen	NP	25T	CE

## SARS-CoV-2 & FLU A/B

### Rapid Antigen Test Kit

This device is intended for the *in vitro* qualitative detection and differentiation of SARS-CoV-2 and influenza A / B antigens in nasal and nasopharyngeal swab samples.



For seeing the Interpretation follow [page 35 Interpretation G](#)

#### Advantages

- Simultaneously detects and differentiates SARS-CoV-2 and Influenza A/B
- Excellent sensitivity at the early phase of infection
- Successfully detects Omicron variants
- Simple procedure for minimum invasion and hands-on-time
- Ergonomic design for minimum risk of contamination

#### Test Procedure



Ref. No	Target	Specimen	Kit Size	Certificates
VSCD08	SARS-CoV-2 & FLU A/B Antigen	N/NP	25T	CE



# Strep A

## Rapid Test Kit

Test kit for the rapid qualitative detection of *Group A Streptococcal* antigen from oropharyngeal swab samples.

### Advantages

- Assists the diagnosis of upper respiratory infectious diseases including scarlet fever, pharyngitis and tonsillitis
- Less-invasive sampling
- Safe and simple procedure
- Fast and accurate results
- Visual and clear interpretation



For seeing the Interpretation follow [page 34 Interpretation A](#)

### Test Procedure



Ref. No	Target	Specimen	Kit Size	Certificates
VMD36	Group A Streptococcal Antigen	OP	25T	CE

# SARS-CoV-2 & FLU A/B & RSV

## Combo Rapid Test Kit

It is created as *in vitro* differentiative detection for SARS-CoV-2 & FLU A/B & RSV antigens in human nasopharyngeal and nasal swab samples.

### Advantages

- Simultaneously detects and differentiates SARS-CoV-2, Influenza A/B, and RSV
- Excellent sensitivity
- Easy-to-follow procedure
- Accurate and sensitive result
- Result available within 15 minutes
- Already filled tube



For seeing the Interpretation follow [page 36 Interpretation K](#)

### Test Procedure

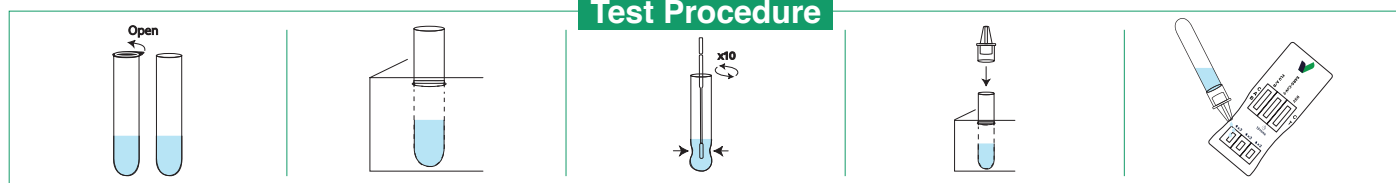

Ref. No	Target	Specimen	Kit Size	Certificates
VMD71	SARS-CoV-2,FLU A/B,RSV Antigen	N, NP	25T	CE

# RESPIRATORY DISEASES RAPID TEST

## FLU A/B & RSV Combo Test Kit

Test kit is a lateral flow sandwich assay designed for *in vitro* qualitative detection of the nucleocapsid antigen of Influenza A/B (FLU A/B), and Respiratory Syncytial Virus (RSV) in human nasopharyngeal swab samples.



### Advantages

- For professional use only
- Already filled buffer tubes
- Easy-to-follow procedure
- Results available within 15 minutes
- Accurate and rapid results



For seeing the Interpretation follow [page 36 Interpretation L](#)

### Test Procedure



Ref. No	Target	Specimen	Kit Size	Certificates
VMD77	FLU A/B and RSV antigens	NP	25T	CE

## FLU A/B & RSV & ADV Combo Test Kit

Test kit is a lateral flow sandwich assay designed for *in vitro* qualitative detection of the nucleocapsid antigen of Influenza A/B (FLU A/B), Respiratory Syncytial Virus (RSV) and Adenovirus (ADV) in human nasopharyngeal swab samples.

### Advantages

- For professional use only
- Already filled buffer tubes
- Easy-to-follow procedure
- Results available within 15 minutes
- Accurate and rapid results



For seeing the Interpretation follow [page 36 Interpretation M](#)

### Test Procedure

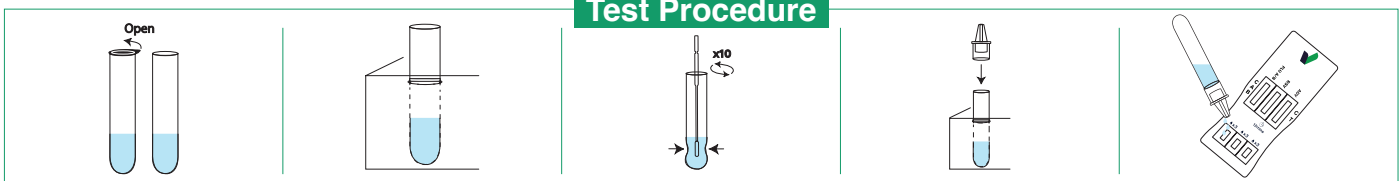

Ref. No	Target	Specimen	Kit Size	Certificates
VMD78	FLU A/B, RSV and ADV antigens	NP	25T	CE



# SARS-CoV-2 & Flu A/B & RSV & ADV Combo Test Kit

Test kit is a lateral flow sandwich assay designed for *in vitro* qualitative detection of the nucleocapsid antigen of SARS-CoV-2, Influenza A/B, Respiratory Syncytial Virus (RSV) and Adenovirus (ADV) in human nasopharyngeal swab samples.



## Advantages

- For professional use only
- Already filled buffer tubes
- Easy-to-follow procedure
- Results available within 15 minutes
- Accurate and rapid results



For seeing the Interpretation follow [page 36 Interpretation N](#)

## Test Procedure



Ref. No	Target	Specimen	Kit Size	Certificates
VMD79	SARS-CoV-2, FLU A/B, RSV and ADV antigens	NP	25T	CE

## Sample Collection

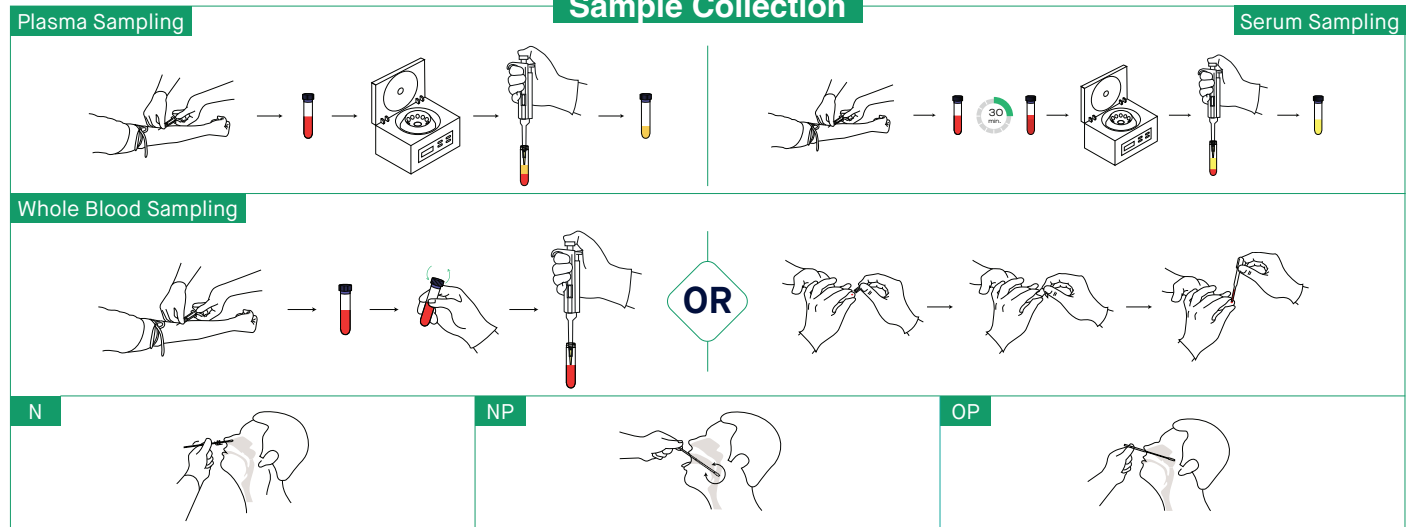

Ref. No	Name	Specimen	Kit Size	Certificates
VSCD02ST	SARS-CoV-2 Rapid Antigen Test (Nasal)	N	1/2/5T	CE 1434
VSCD10	SARS-CoV-2 & FLU A/B Antigen Combo Test	N/NP	25T	TGA
VSCD10ST	SARS-CoV-2 & FLU A/B Antigen Combo Test (Nasal)	N	1/2/5T	TGA
VSCD01	SARS-CoV-2 IgG/IgM Test	S/P/WB	25T	CE
VMD17	Influenza A/B Rapid Test Kit	N/NP	25T	CE
VMD66	RSV Rapid Test Kit	NP	25T	CE
VSCD08	SARS-CoV-2 & FLU A/B Rapid Antigen Test	N/NP	25T	CE
VSCD02	SARS-CoV-2 Rapid Antigen Test	N/NP/OP	25T	CE
VMD36	Strep A Rapid Test Kit	OP	25T	CE
VMD71	SARS-CoV-2 & FLU A/B & RSV Combo Rapid Test Kit	N/NP	25T	CE
VMD77	FLU A/B & RSV Combo Test Kit	NP	25T	CE
VMD78	FLU A/B & RSV & ADV Combo Test Kit	NP	25T	CE
VMD79	SARS-CoV-2 & Flu A/B & RSV & ADV Combo Test Kit	NP	25T	CE

# GASTROINTESTINAL DISEASES RAPID TEST

## Rota-Adeno Tri-Line Rapid Test

This device is intended for the *in vitro* qualitative detection and differentiation of antigens specific to Rotavirus and Adenovirus in fecal samples.

### Advantages

- Simultaneously detects and differentiates Adenovirus and Rotavirus infections
- Assists in the diagnosis of acute diarrheal disease and acute gastroenteritis
- Ergonomic design for minimum risk of contamination
- Qualitative, easy-to-read results in 15 minutes
- Assists the prevention of further transmission



For seeing the Interpretation follow [page 35 Interpretation H](#)

### Test Procedure



Ref. No	Target	Specimen	Kit Size	Certificates
VMD075	Rotavirus & Adenovirus Antigen	Feces	20T	CE

## H.Pylori Ag Rapid Test Kit

Test kit serves the qualitative detection of *H. pylori* antigen in human fecal samples.



### Advantages

- Assists to the diagnosis of *H. pylori* infection, to check the effectiveness of treatment and to confirm the eradication of *H. pylori* in patients
- The diet of the patient does not affect the result
- Minimized contamination risk
- Accurate and fast results
- Simple and safe specimen collection



For seeing the Interpretation follow [page 34 Interpretation A](#)

### Test Procedure

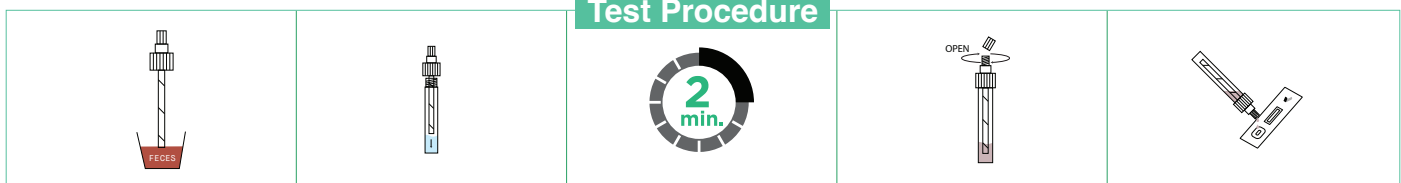

Ref. No	Target	Specimen	Kit Size	Certificates
VMD16	<i>H.pylori</i> Antigen	Feces	20T	CE

# Norovirus

## Rapid Test Kit

Test kit is created for qualitatively determining the presence of Norovirus in human fecal samples.

### Advantages

- Support the diagnosis of norovirus infection
- Collection apparatus minimizes specimen handling and contamination
- Virtual interpretation
- Accurate results within minutes
- Effortless and easy sampling



For seeing the Interpretation follow **page 34 Interpretation A**

### Test Procedure



Ref. No	Target	Specimen	Kit Size	Certificates
VMD41	Norovirus Antigen	Feces	20T	CE

Ref. No	Name	Specimen	Kit Size	Certificates
VMD07	Rota-Adeno Tri-Line Test Kit	F	20T	CE
VMD16	H.Pylori Ag Rapid Test Kit	F	20T	CE
VMD24	Rotavirus Rapid Test Kit	F	20T	CE
VMD35	H.Pylori Ab Rapid Test Kit	S/P	25T	CE
VMD40	Adenovirus Rapid Test Kit	F	20T	CE
VMD41	Norovirus Rapid Test Kit	F	20T	CE

# TROPICAL DISEASES RAPID TEST

## Malaria P.F/Pan Rapid Test Kit

One single test for the simultaneous qualitative detection of four different circulating antigens in human whole blood samples: *Plasmodium falciparum* (P.f.), *Plasmodium vivax*, (P.v.) *Plasmodium ovale* (P.o.), *Plasmodium malariae* (P.m.).

### Advantages

- Comprehensive testing
- Highly accurate results within minutes
- Clear detection
- Minimized complexity
- No need for extra analyzer



For seeing the Interpretation follow [page 34 Interpretation D](#)

### Test Procedure



Ref. No	Target	Specimen	Kit Size	Certificates
VMD21	Malaria P.F./Pan Antigen	WB	25T	CE

## Malaria P.F/P.V Rapid Test Kit

Test kit simultaneously detects and differentiates specific antigens of *Plasmodium falciparum* (P.f.) and *P. vivax* (P.v.) in human whole blood samples.



### Advantages

- 2 in 1 test for determination of both P.f. and P.v.
- Aids in controlling the influence of anti-malarial medication
- Visual and clear interpretation
- Simplified and safe procedure
- All you need in the test box

For seeing the Interpretation follow [page 34 Interpretation E](#)

### Test Procedure



Ref. No	Target	Specimen	Kit Size	Certificates
VMD22	Malaria P.F./P.V. Antigen	WB	25T	CE

# Dengue IgG/IgM & NS1 Ag Combo Rapid Test Kit

Test kit qualitatively detects dengue virus specific IgG and IgM antibodies and dengue virus NS1 antigen in human serum, plasma, and whole blood samples.

## Advantages

- Enables simultaneous detection and differentiation of Dengue Ag & Ab
- Results available in minutes
- Can help distinguish between primary and secondary dengue infections
- Screening from acute phase to recovery phase of infection
- Simple, safe, and accurate



## Test Procedure

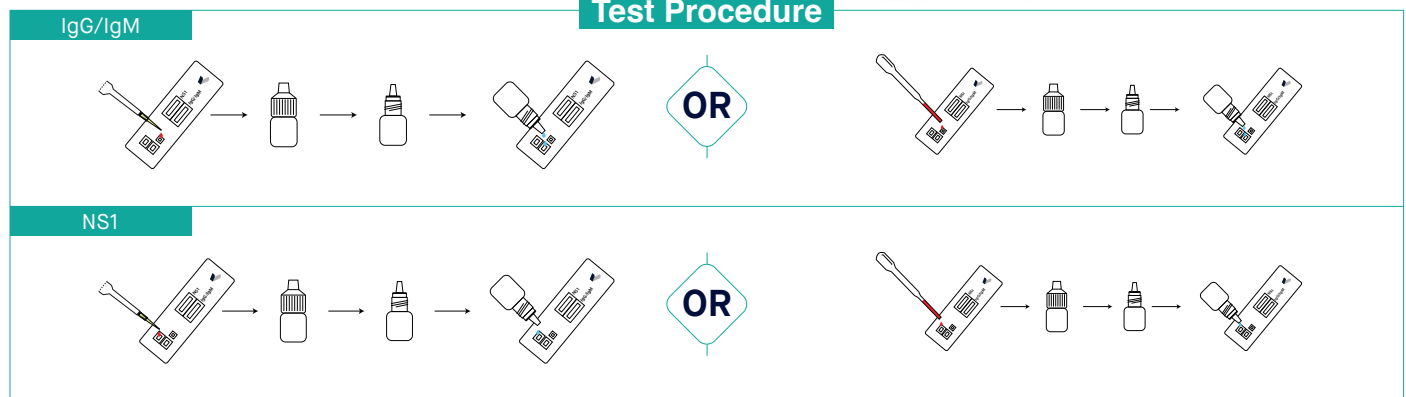

For seeing the interpretation  
color page 34 Interpretation A

Ref. No	Target	Specimen	Kit Size	Certificates
VMD06	Dengue Specific IgG/IgM Antibodies & NS1 Antigen	S/P/WB	25T	CE

## Sample Collection

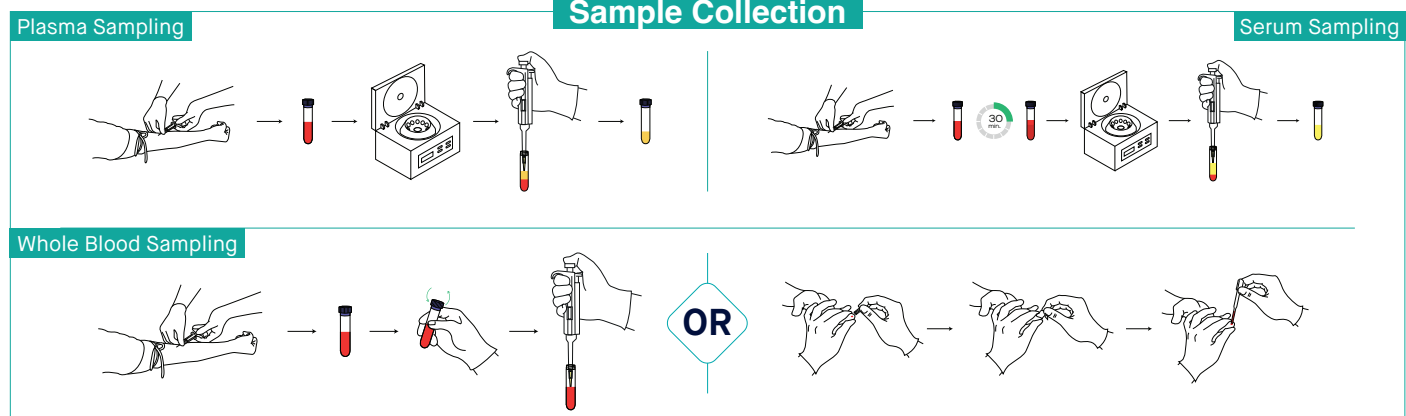

Ref. No	Name	Specimen	Kit Size	Certificates
VMD06	Dengue IgG/IgM & NS1 Combo Rapid Test Kit	S/P/WB	25T	CE
VMD08	Dengue NS1 Ag Rapid Test Kit	S/P/WB	25T	CE
VMD20	Malaria P.F Rapid Test Kit	WB	25T	CE
VMD21	Malaria P.F/Pan Rapid Test Kit	WB	25T	CE
VMD22	Malaria P.F/P.V Rapid Test Kit	WB	25T	CE
VMD29	Typhoid IgG/IgM Rapid Test Kit	S/P/WB	25T	CE
VMD38	Dengue IgG/IgM Rapid Test Kit	S/P/WB	25T	CE

# TUMOR MARKERS RAPID TEST

## FOB

### Rapid Test Kit

Test kit is created for the qualitative detection of Hemoglobin (hb) in human fecal samples. It enables early detection of lower gastrointestinal disorders, such as colorectal cancers and adenomas.

#### Advantages

- Detects low levels of fecal occult blood (hHB  $\geq$  50 ng/mL)
- Results are not affected by the diet of the patient
- Effective design to minimize contamination risk
- Accurate and fast results
- Uses minimal sample volume



For seeing the Interpretation follow [page 34 Interpretation A](#)

#### Test Procedure

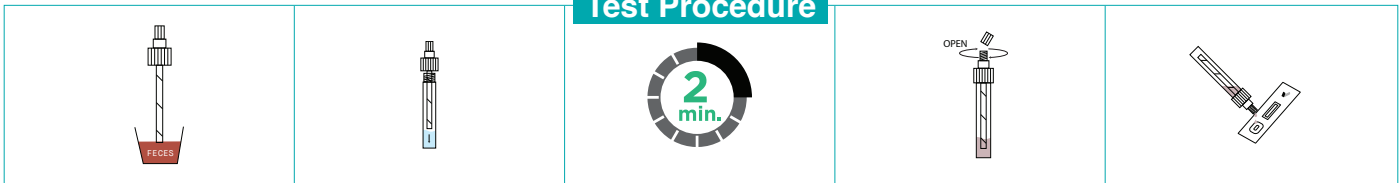

Ref. No	Target	Specimen	Kit Size	Certificates
VMD09	Human Occult Blood	F	20T	CE

## PSA

### Rapid Test Kit

Test kit qualitatively determines human prostate specific antigen (PSA) in human serum, plasma, and whole blood samples.



For seeing the Interpretation follow [page 34 Interpretation A](#)

#### Advantages

- Assists the diagnosis of prostate gland problems including prostate cancer
- Contributes to the early diagnosis
- Easy procedure with few steps
- Fast, sensitive, and accurate results
- No special equipment required

#### Test Procedure



Ref. No	Target	Specimen	Kit Size	Certificates
VMD46	PSA	S/P/WB	25T	CE

# AFP

## Rapid Test Kit

Test kit qualitatively detects alpha fetoprotein (AFP) in human serum, plasma, and whole blood samples.

### Advantages

- Supports the diagnosis of primary hepatocellular carcinomas, testicular teratocarcinomas and neural tube defects
- High rates of sensitivity and specificity
- Simple procedure
- Clear, fast, and accurate results
- Easy-to-handle design



For seeing the Interpretation follow **page 34 Interpretation A**

### Test Procedure

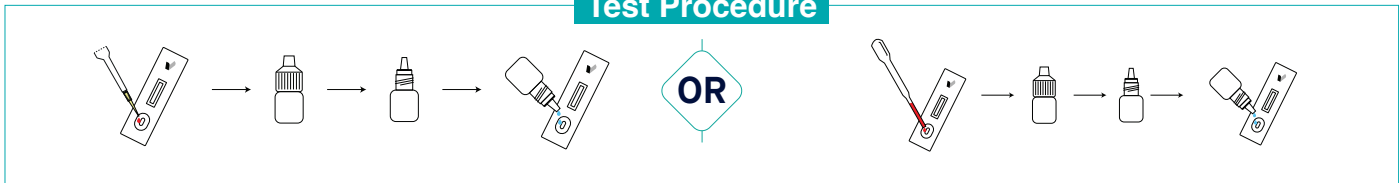

Ref. No	Target	Specimen	Kit Size	Certificates
VMD44	AFP	S/P/WB	25T	CE

### Sample Collection

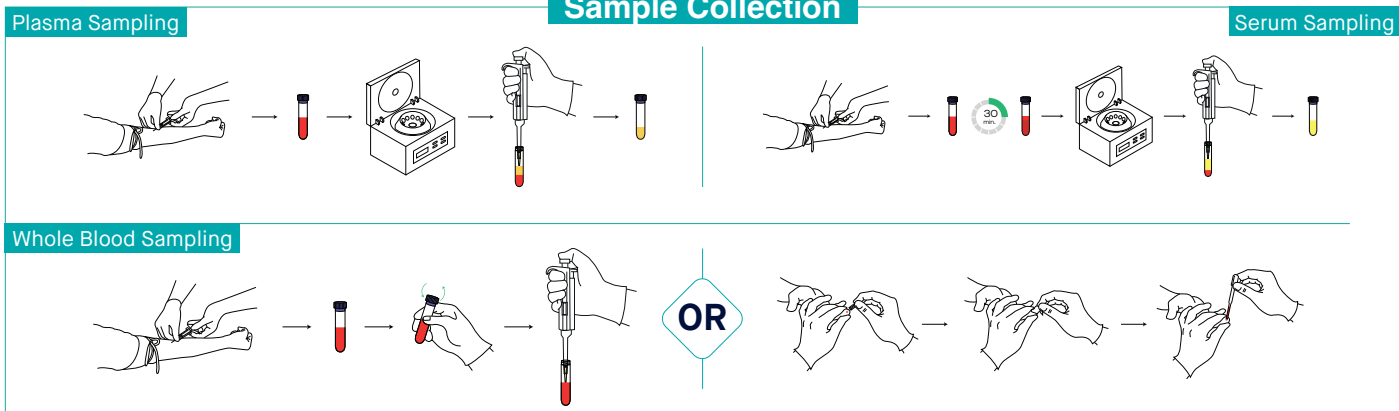

Ref. No	Name	Specimen	Kit Size	Certificates
VMD09	FOB Rapid Test Kit	F	20T	CE
VMD46	PSA Rapid Test Kit	S/P/WB	25T	CE
VMD44	AFP Rapid Test Kit	S/P/WB	25T	CE
VMD45	CEA Rapid Test Kit	S/P/WB	25T	CE



# FERTILITY RAPID TEST

## hCG

### Rapid Test Kit

Test kit is a simple point-of-care test enabling determination of human chorionic gonadotropin (hCG) in human urine samples.



#### Advantages

- Aids in the early detection of pregnancy
- Accurate results as early as the first day of a missed period
- Two types of test procedure options
- Instant and accurate results
- Safe and minimal design



For seeing the Interpretation follow [page 34 Interpretation A](#)

#### Test Procedure

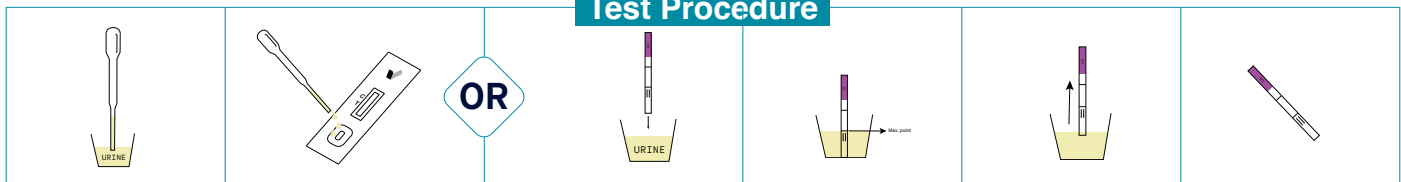

Ref. No	Target	Specimen	Kit Size	Certificates
VMD59	Human Chorionic Gonadotropin	U	25/50/100T	CE



# Ovulation LH Rapid Test Kit

Test kit qualitatively detects Luteinizing Hormone (LH) in human urine samples.

## Advantages

- Assists the prediction of the fertility cycle for females
- Accurate results as early as the first day of a missed period
- Safe and easy sampling
- Fast and accurate results
- Minimalistic design



For seeing the Interpretation follow **page 34 Interpretation A**

## Test Procedure

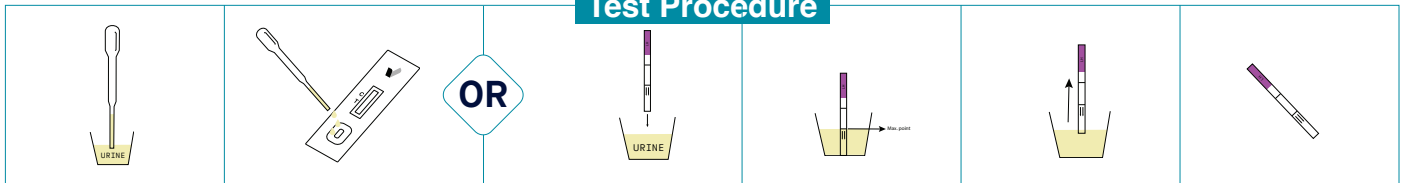

Ref. No	Target	Specimen	Kit Size	Certificates
VMD61	Luteinizing Hormone	U	25T	CE

Ref. No	Name	Specimen	Kit Size	Certificates
VMD61	Ovulation LH Rapid Test Kit	U	25T	CE
VMD59	hCG Rapid Test Kit	U	25/50/100T	CE

## OTHERS RAPID TEST

# Toxo IgG/IgM Rapid Test Kit

Test kit is created for the qualitative detection and differentiation of Toxoplasma specific IgG and IgM antibodies in human serum, plasma, and whole blood samples.

### Advantages

- Helps to screen both primary and previous Toxoplasma infections
- Aids in the determination of the infection status and the immunity status
- Simple and safe test operation
- Maximized sensitivity
- Accurate results within minutes



For seeing the Interpretation follow [page 34 Interpretation B](#)

### Test Procedure

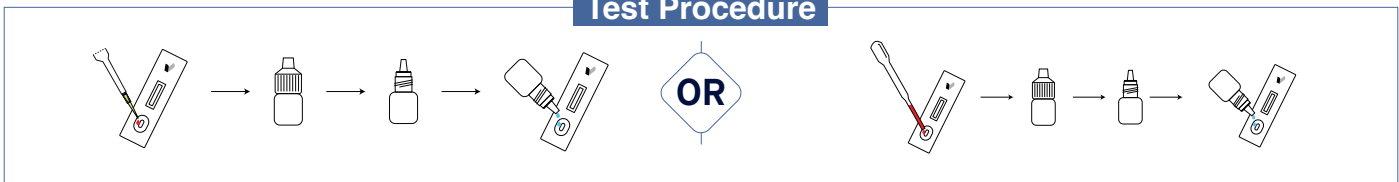

Ref. No	Target	Specimen	Kit Size	Certificates
VMD28	Toxoplasma Specific IgG/IgM Antibodies	S/P/WB	25T	CE

# Troponin I Rapid Test Kit

Test kit is designed for the qualitative detection of cardiac Troponin I protein in human serum, plasma, and whole blood samples.



For seeing the Interpretation follow [page 34 Interpretation A](#)

### Advantages

- Aids in the diagnosis of myocardial ischemia, myocardial infarction, and ACS
- Safe and simple procedure
- All you need is in the box
- Fast and accurate results
- Simple, clear, and visual interpretation

### Test Procedure

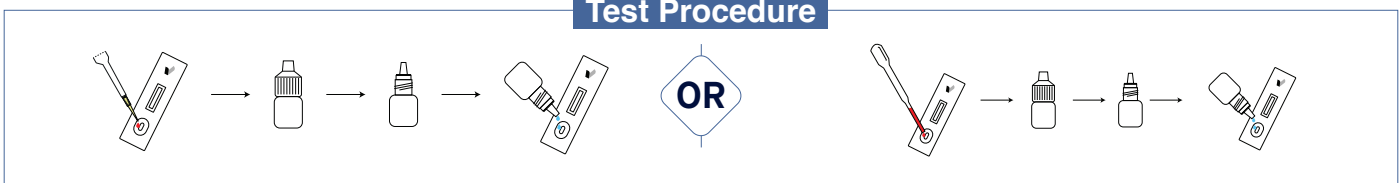

Ref. No	Target	Specimen	Kit Size	Certificates
VMD49	Troponin I	S/P/WB	25T	CE

# Rubella IgG/IgM Rapid Test Kit

Test kit enables rapid differential detection of Rubella-specific IgM and IgG antibodies in human serum, plasma, and whole blood samples.

## Advantages

- Rapid results with high accuracy
- Useful for identifying early and past Rubella infections
- Clear and simple interpretation
- Easy-to-follow procedure
- Everything you need is in the box



For seeing the Interpretation follow **page 34 Interpretation B**

## Test Procedure

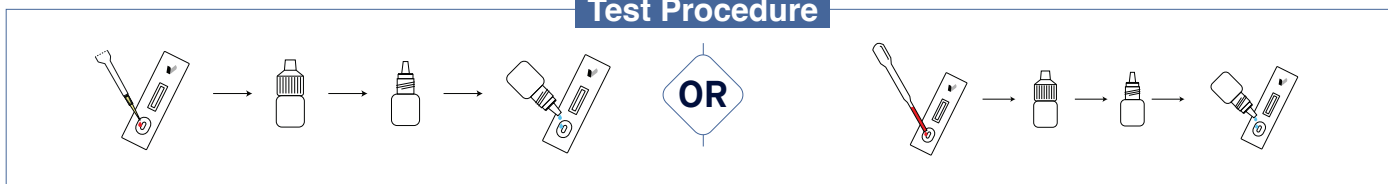

Ref. No	Target	Specimen	Kit Size	Certificates
VMD26	Rubella Specific IgG/IgM Antibodies	S/P/WB	25T	CE

## Sample Collection

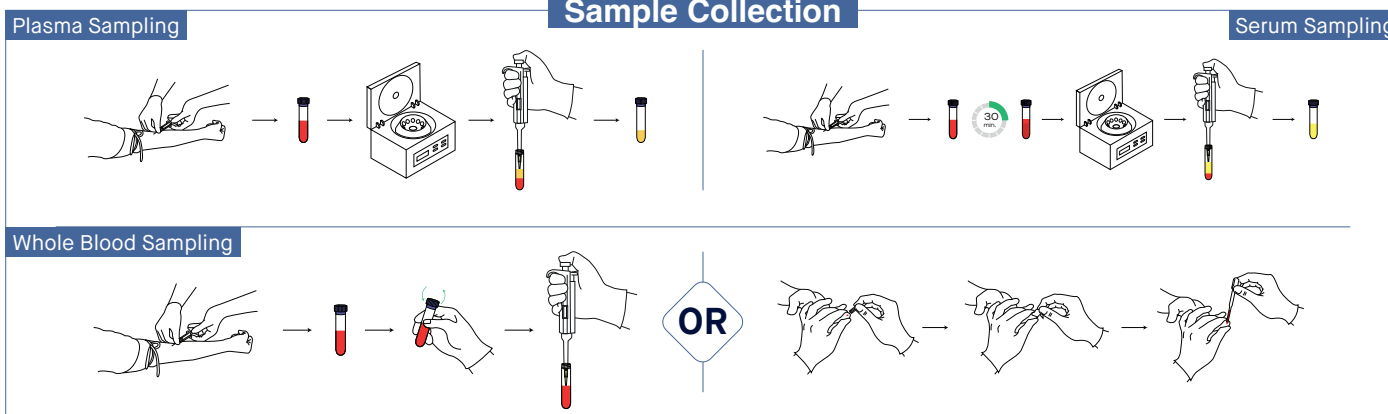

Ref. No	Name	Specimen	Kit Size	Certificates
VMD28	Toxo IgG/IgM Rapid Test Kit	S/P/WB	25T	CE
VMD49	Troponin I Rapid Test Kit	S/P/WB	25T	CE
VMD26	Rubella IgG/IgM Rapid Test Kit	S/P/WB	25T	CE

## DRUG OF ABUSE (DOA)

# Saliva Multi-Drug Test Cup

It is created for the qualitative detection of total of 14 drugs and drug metabolites (AMP, BAR, BZO, BUP, COC, THC, MET, MTD, MDMA, MOP, OXY, PCP, PPX, and TCA) simultaneously by using human oral fluid samples.

### Advantages

- One-step procedure
- Rapid results
- Clear interpretation
- All required material in box
- Compact design



Drugs and drug metabolites we can screen		
Drug	Description	Cut-off (ng/mL) for Oral Fluid Sample
AMP	Amphetamine	50
BAR	Barbiturates	50
BZO	Benzodiazepines	50
BUP	Buprenorphine	10
COC	Cocaine	20
THC	Marijuana	20
MET	Methamphetamine	50
MTD	Methadone	50
MDMA	MDMA Ecstasy	50
MOP	Morphine	40
OXY	Oxycodone	20
PCP	Phencyclidine	20
PPX	Propoxyphene	50
TCA	Tricyclic Antidepressants	100

Ref. No	Name	Specimen	Kit Size	Certificates
VDDOA04	Saliva Multi-Drug Test Cup	S	25/50T	CE

\*S: Saliva

# Urine Multi-Drug Test Cup

It is created for the qualitative detection of total of 14 drugs and drug metabolites (AMP, BAR, BZO, BUP, COC, THC, MET, MTD, MDMA, MOP, OXY, PCP, PPX, and TCA) simultaneously by using human urine samples.

## Advantages

- One-step procedure
- Ergonomic design
- Results are appropriate to be photocopied
- Results within 60 seconds for negative samples
- Maximized accuracy



Drugs and drug metabolites we can screen		
Drug	Description	Cut-off (ng/mL) for Urine Sample
AMP	Amphetamine	1000
BAR	Barbiturates	300
BZO	Benzodiazepines	300
BUP	Buprenorphine	10
COC	Cocaine	300
THC	Marijuana	50
MET	Methamphetamine	1000
MTD	Methadone	300
MDMA	MDMA Ecstasy	500
MOP	Morphine	300
OXY	Oxycodone	100
PCP	Phencyclidine	25
PPX	Propoxyphene	300
TCA	Tricyclic Antidepressants	1000

Ref. No	Name	Specimen	Kit Size	Certificates
VDDOA02	Urine Multi-Drug Test Cup	U	10/50T	CE

\*U: Urine

# DRUG OF ABUSE (DOA)

## Cotinine (COT) Rapid Test Kit

This device is intended for the *in vitro* qualitative detection of cotinine (COT) in urine samples.

### Advantages

- Excellent marker of tobacco consumption and nicotine use
- Qualitative, easy-to-read results in 15 minutes
- High sensitivity and specificity
- Simple, non-invasive, one-step procedure
- Detects cotinine (COT) for 2- 4 days following the last cigarette



For seeing the Interpretation follow [page 34 Interpretation A](#)

### Test Procedure

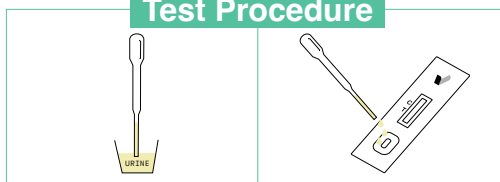

Ref. No	Target	Specimen	Kit Size	Certificates
VDDOA13	Cotinine (COT)	U	25T	CE

# MOLECULAR DIAGNOSTIC



## SARS-CoV-2 Detection RT-qPCR Kit

The CHAINFOR SARS-CoV-2 Detection RT-qPCR kit is intended for in vitro diagnosis of SARS-CoV-2 nucleic acids from nasopharyngeal aspirate/lavage, bronchoalveolar lavage, nasopharyngeal swab, and oropharyngeal swab qualitatively.

### Advantages

- Simple and rapid detection by qPCR
- No cross-reaction with common human respiratory CoV or MERS
- Fast workflow: <60 min
- No interfering with potential substance
- Targeting *N genes* in the SARS-CoV genome based on the readout of the FAM channel
- Internal control is based on the readout of the HEX channel
- Analytical sensitivity is >95%, Clinical sensitivity is 97%



Ref. No	Target	Storage	Kit Size	Certificates
CFP01	SARS-CoV-2 <i>N gene</i>	-25°C~ -15°C	100 R	CE



## SARS-CoV-2 & Flu A/B Detection RT-qPCR Kit

CHAINFOR SARS-CoV-2 & Flu A/B Detection RT-qPCR Kit is intended for in vitro diagnosis to detect and differentiate SARS-CoV-2, Influenza A, and Influenza B viruses in human respiratory specimens.

### Advantages

- Simple and rapid detection by qPCR
- Fast workflow: <60 min
- Targeting *N genes* in the SARS-CoV genome based on the readout of the FAM channel
- Targeting Matrix(M) genes in the Influenza A genome based on the readout of the Cy5 channel
- Targeting hemagglutinin (HA) genes in the Influenza B genome based on the readout of the ROX channel
- Low experimental costs and simplicity for the workflow.
- No interfering with potential substance
- Internal control is based on the readout of the HEX channel
- Analytical sensitivity >95%, Clinical sensitivity is 97%



Ref. No	Target	Storage	Kit Size	Certificates
CFP05	SARS-CoV-2 & FLU A/B <i>N gene</i>	-25°C~ -15°C	100 R	CE



## Viral Nucleic Acid Purification Kit

Virasens Viral Nucleic Acid Purification kit enables the purification of viral nucleic acids (DNA and RNA) from samples such as serum, plasma, body fluids, and supernatant of virus-infected cell cultures.

### Advantages

- Fast purification process in 40 min
- The global viral nucleic acid purification system
- No toxic reagent
- Ready-to-use DNA and RNA for any downstream analysis
- The kit includes columns that can effectively remove DNA and RNA impurities.



Ref. No	Name	Storage	Kit Size	Certificates
VIRA01	Viral Nucleic Acid Purification Kit	2°C~ 25°C	100 R	CE



## Genomic DNA Purification Kit From Blood

Virasens Genomic DNA Purification Kit From Blood is designed to purify genomic DNA from fresh or frozen human blood to prepare samples for downstream analysis.

### Advantages

- Fast purification process 25 min
- High-efficiency rate
- No toxic reagent
- Ready-to-use DNA any downstream analysis
- The kit includes columns that can effectively remove DNA impurities.



Ref. No	Name	Storage	Kit Size	Certificates
VIRA02	Virasens Genomic DNA Purification Kit From Blood	2°C~ 25°C	100 R	CE



# VTFOR

## Viral Transport Medium

VTFOR Viral Transport Medium is a transport system used for collecting and transporting cells and viruses from clinical specimens or media to isolate nucleic acids in nucleic acid amplification tests.

### Advantages

- Ready-to-use viral transport kit
- Fast, simple, and inexpensive
- The collection and preservation of samples containing viruses
- Contamination-preventing content
- Flexibility in transport temperature
- Crack-resistant, leak-proof, and stand-up tubes
- Suitable for further testing such as PCR



Ref. No	Name	Storage	Kit Size	Certificates
VTF01	Viral Transport Medium	2°C~ 25°C	100 T	CE

# VNFOR

## Viral Nucleic Acid Transport Medium

VNFOR Viral Nucleic Acid Transport Medium is an extraction buffer used to extract viral nucleic acids from clinical samples or media samples to obtain viral nucleic acids for use in nucleic acid amplification tests.

### Advantages

- Contamination-preventing content
- Flexibility in transport temperature
- Suitable for further testing such as RT-PCR
- Crack-resistant, leak-proof, and stand-up tubes
- Fast, simple, and inexpensive



Ref. No	Name	Storage	Kit Size	Certificates
VNF01	Viral Nucleic Acid Transport Medium	2°C~ 25°C	100 T	CE

# INTERPRETATION

## Interpretation A

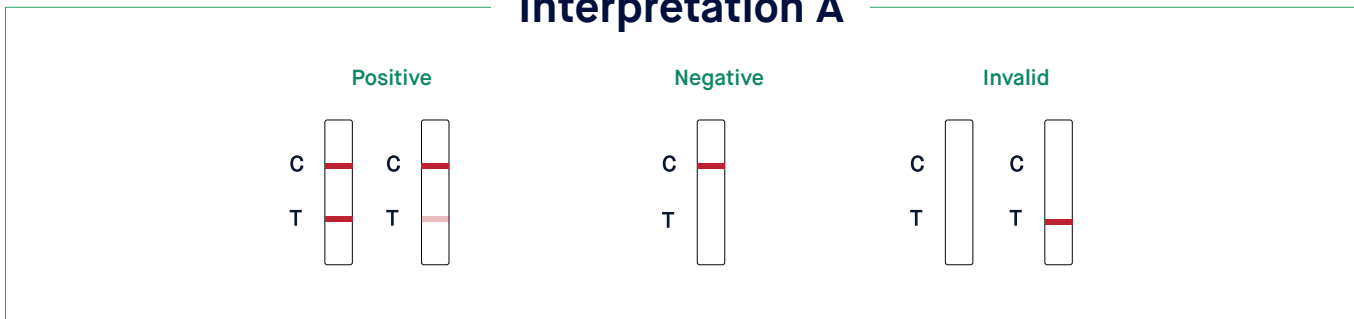

## Interpretation B

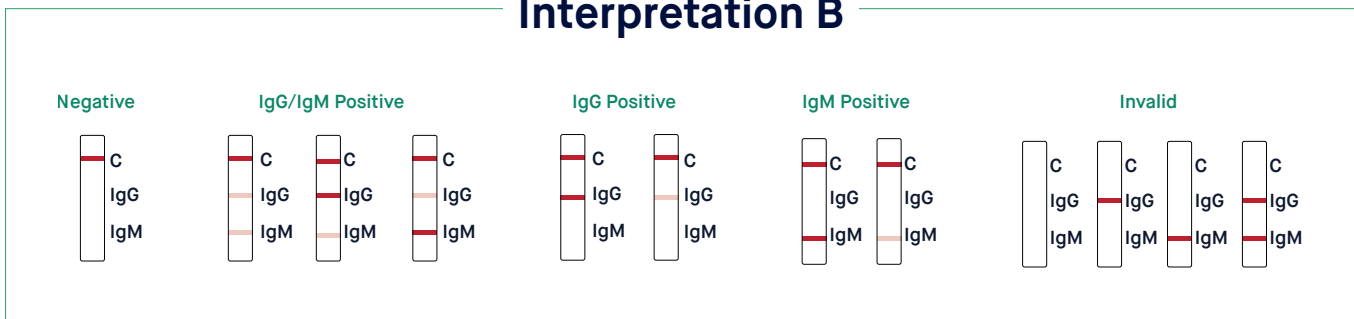

## Interpretation C

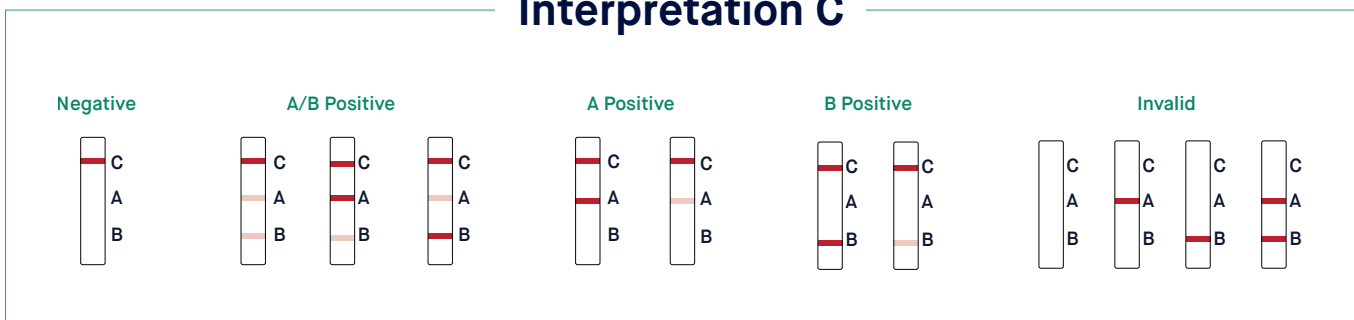

## Interpretation D

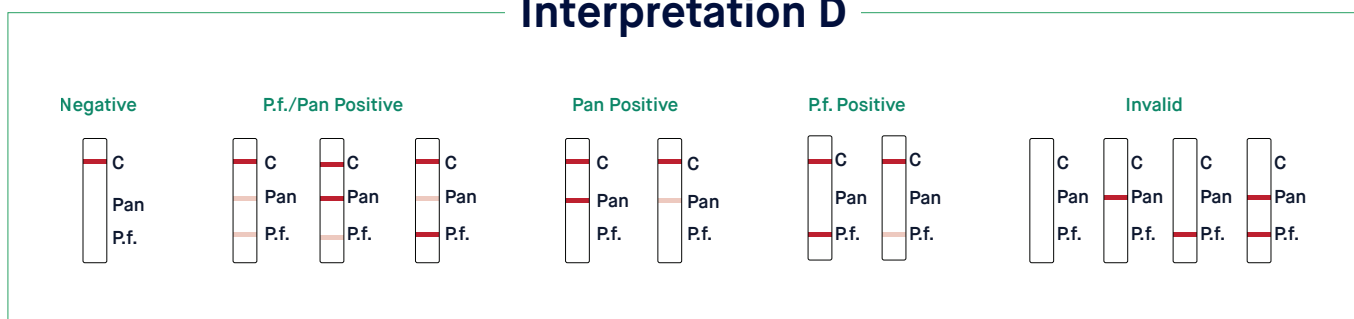

## Interpretation E

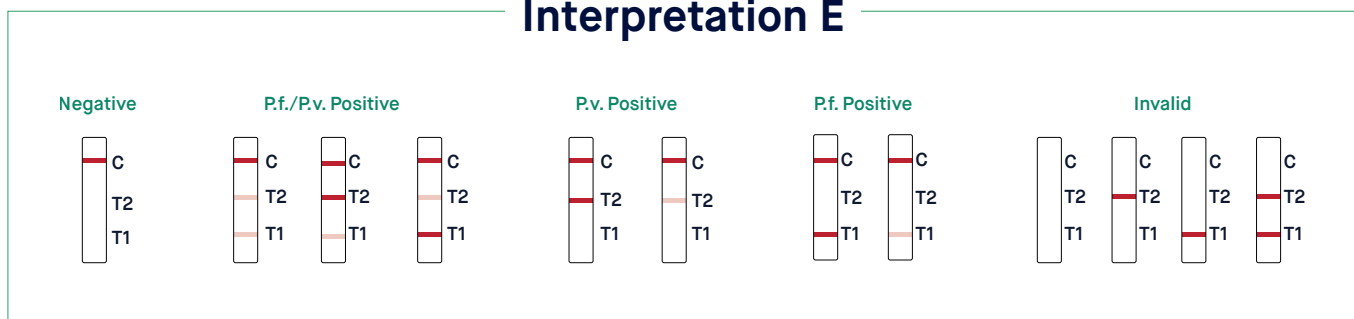

## Interpretation F

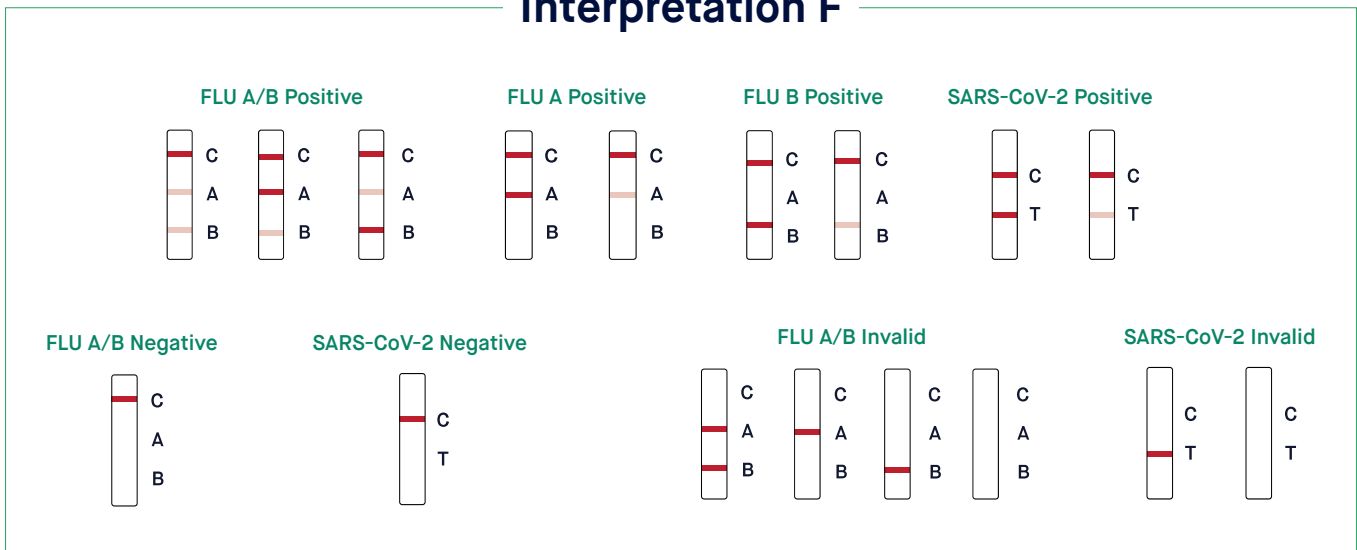

## Interpretation G

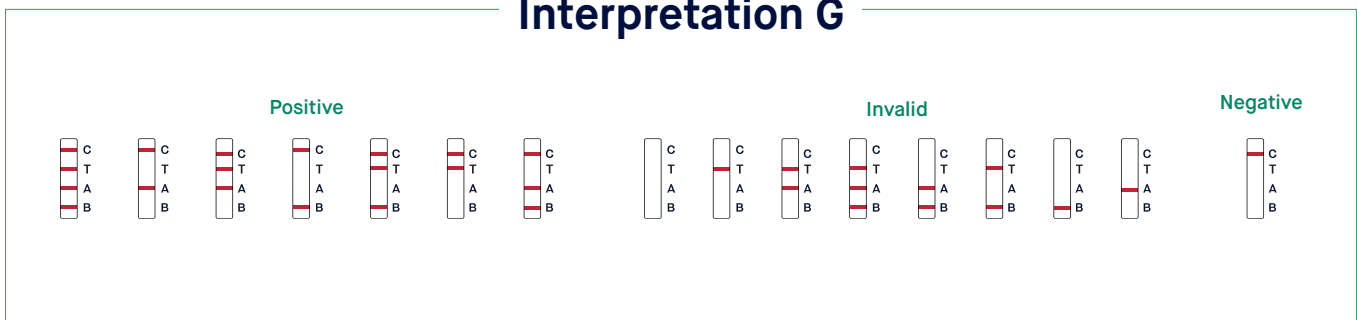

## Interpretation H

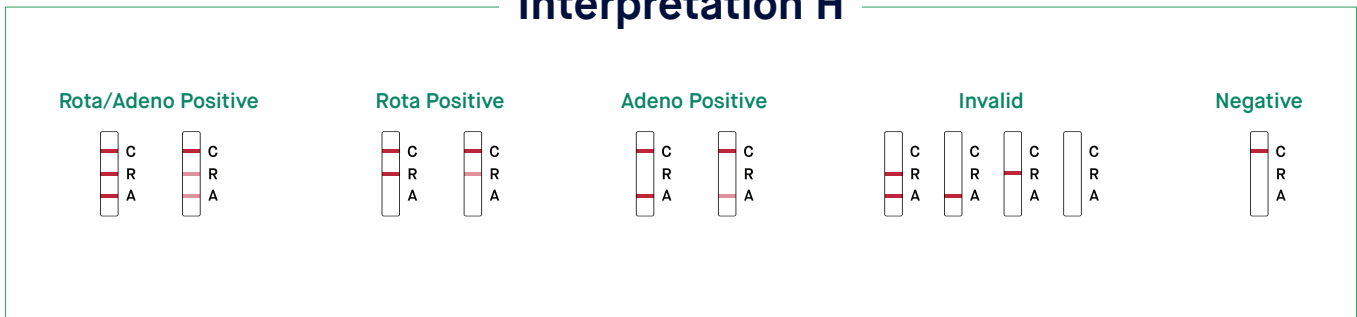

## Interpretation I

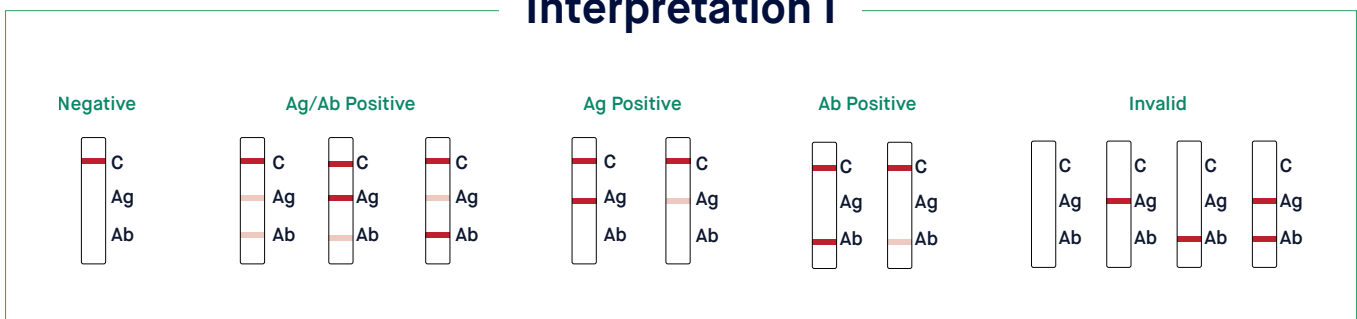

## Interpretation J

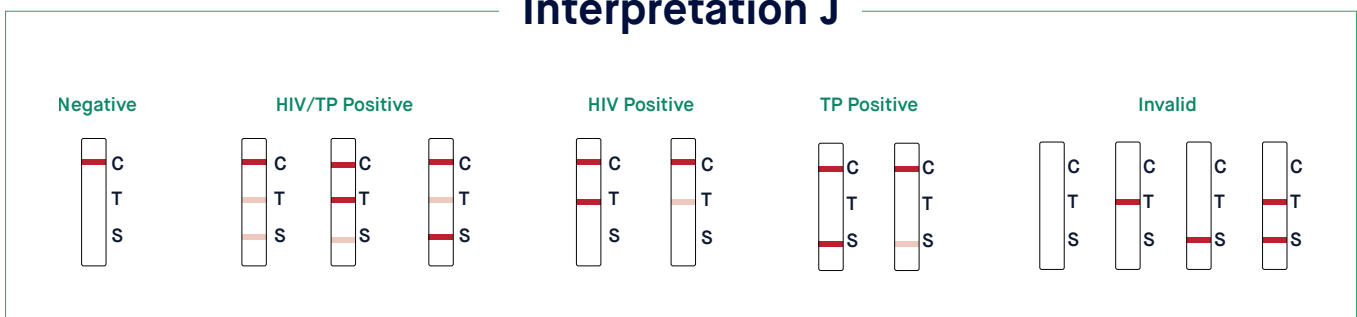

# INTERPRETATION

## Interpretation K

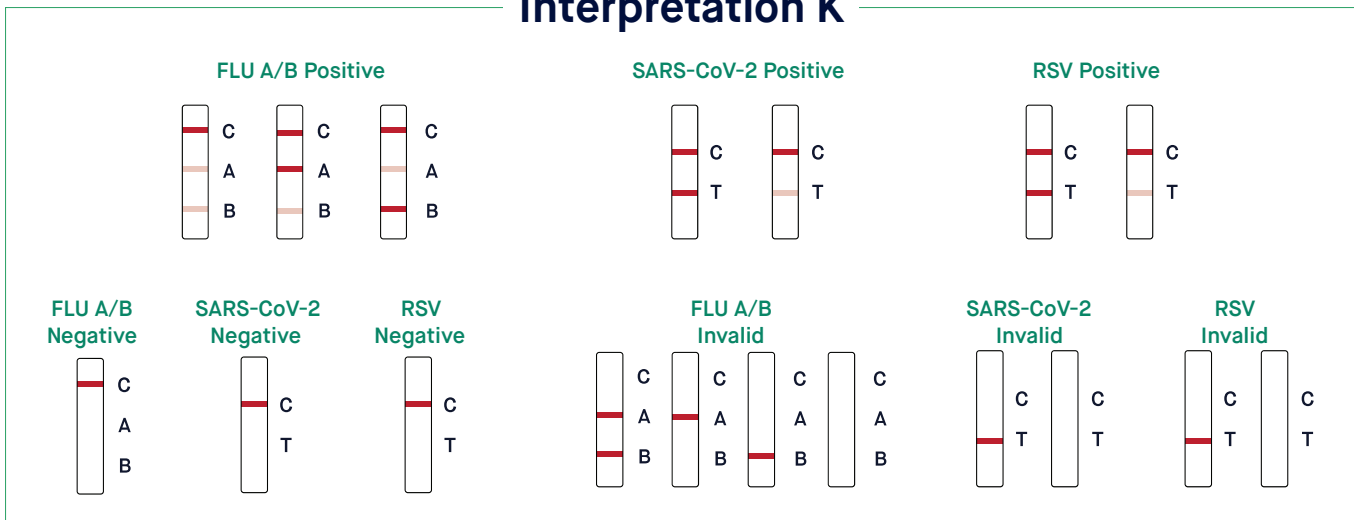

## Interpretation L

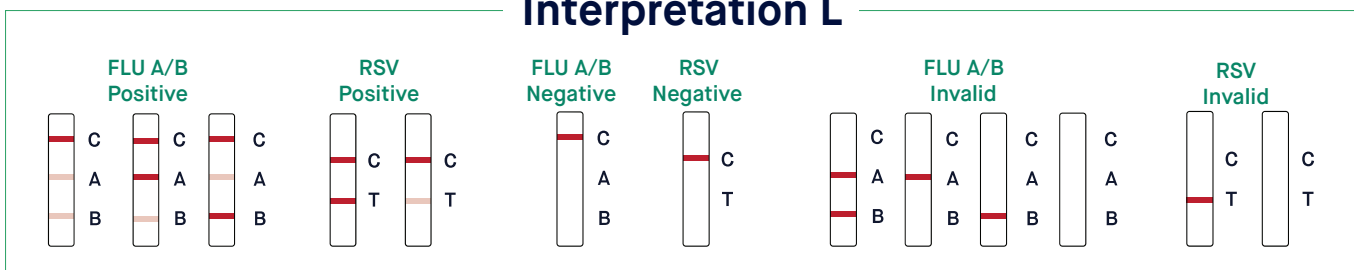

## Interpretation M

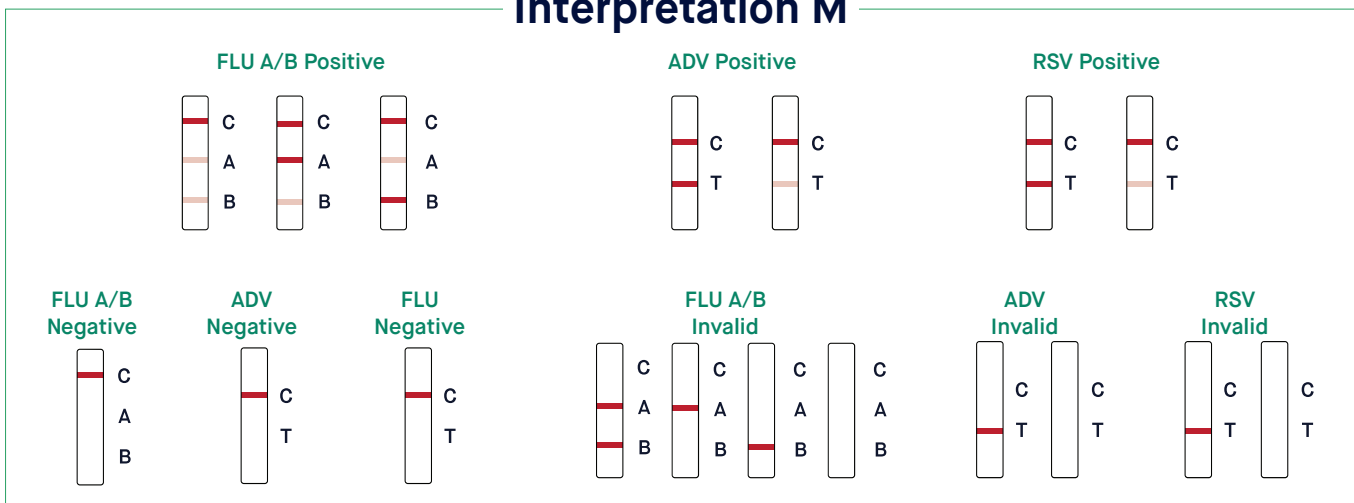

## Interpretation N

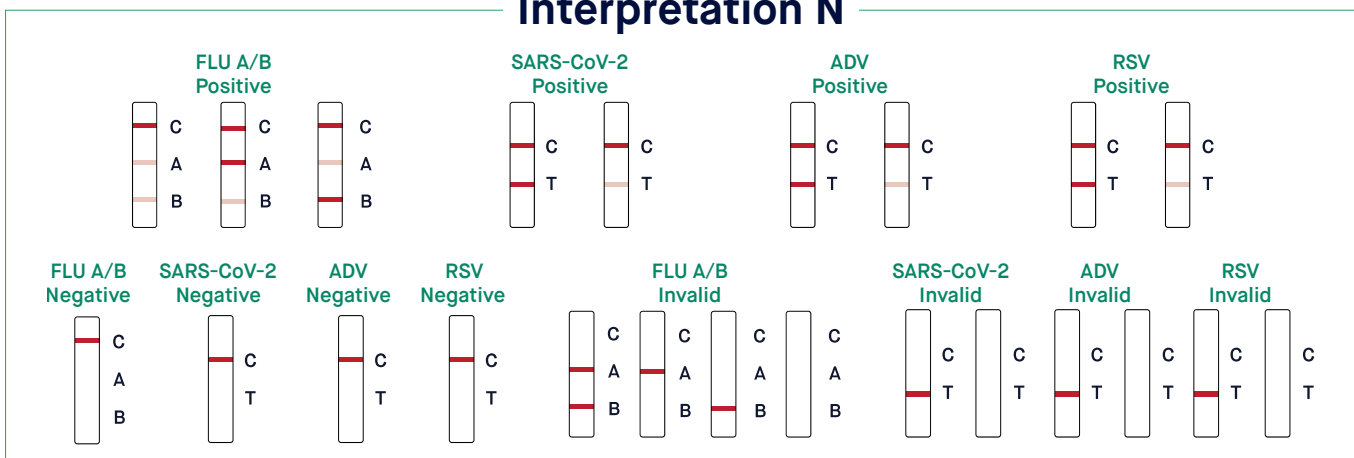

# CERTIFICATES

Certificate of Registration

## G-CERTI *certificate*

hereby certifies that

**VITROSENS BİYOTEKNOLOJİ LTD. ŞTİ.**

Şerifali Mah. Şehit Sk. No:17/1 Ümraniye İstanbul TÜRKİYE  
Şerifali Mah. Şehit Sk. No:17/1 Ümraniye İstanbul TURKEY

meets the Standard Requirements & Scope as following

**ISO 9001:2015** Quality Management Systems

**IN-VITRO DİAGNOSTİK (TANI) ÜRÜNLERİNİN VE CİHAZLARININ ARAŞTIRMA VE GELİŞTİRME, ÜRETİM, PAZARLAMA, İHRACAT VE İTHALAT HİZMETLERİ**

RESEARCH AND DEVELOPMENT, PRODUCTION, MARKETING, EXPORT AND IMPORT SERVICES OF IN-VITRO DIAGNOSTIC (DIAGNOSIS) PRODUCTS AND DEVICES

Certificate No : GCTB-0208-QC  
Initial Date : 29. Mar. 2022 Issue Date : 29. Mar. 2022  
Expiry Date : 28. Mar. 2025 Valid period : 29. Mar. 2022 ~ 28. Mar. 2023

Signed for and on behalf of GCERTI  
President I.K. Cho

To verify the validity of this certificate please visit : [www.gcerti.com](http://www.gcerti.com)  
Korea, Seoul, Eunhyejeong-gu, Eunhyejeong-ro, 88, 1GF. Surveillance audits shall be conducted at least once a calendar year, except in recertification years. This is to certify that the Management Systems of this company has been found to conform to the above. If the certified client does not allow surveillance, recertification audits, certificate should be returned to GCERTI. This certificate remains the property of GCERTI and this certificate is recognized by GCERTI.

**IAS** ACCREDITED Management System Certification Body MSCB-113

**IAF** ACCREDITED MANAGEMENT SYSTEM CERTIFICATION BODY MSCB-113

**G-CERTI** SYSTEM SERVICES MSCB-113

INSTITUTE OF GLOBAL CERTIFICATION

Institute of Global Certification  
**IIGIC**

Management System Certification Body No. MSCB-105

## CERTIFICATE

No. 22-B-1311 Rev. 0

**VITROSENS BİYOTEKNOLOJİ LTD. ŞTİ.**

Şerifali Mah. Şehit Sk. No:17/1 Ümraniye İstanbul TÜRKİYE  
Company Reg. No.: 9250960962

has documented and implemented system in compliance with the requirements of

**ISO 13485:2016** certification  
**Medical Devices Quality Management System**  
for  
**RESEARCH AND DEVELOPMENT, PRODUCTION, MARKETING, EXPORT AND IMPORT SERVICES OF IN-VITRO DIAGNOSTIC (DIAGNOSIS) PRODUCTS (TEST KITS FOR CLINICAL CHEMISTRY, IMMUNOLOGY, HAEMATOLOGY, IMMUNOHEMATOLOGY, MICROBIOLOGY, INFECTIOUS IMMUNOLOGY, HISTOLOGY, CYTOLOGY, GENETIC TESTING)**

Technical Area: 14, 15, 16, 17, 18, 19, 20, 21, 38

The certificate is issued on the basis of the results mentioned in the pertinent audit report. Validity of the certificate is conditionally limited by positive results of surveillance audits, which the certified company is committed to undergo.

This certificate can be invalid if the certificate holder does not fulfill the conditions set out in the certification agreement.

Initial issue date: Mar. 25. 2022  
Expire date: Mar. 24. 2025

**G. Gilbert**  
G. Gilbert  
Head of Certification Body

**IIGIC** ISO 13485 CERTIFIED  
**IAS** ACCREDITED  
**IAF** ACCREDITED

Rm. 501, Daebyeong techno town, 638, Seobusset-gil, Geumcheon-gu, Seoul, Republic of Korea  
[www.igcert.org](http://www.igcert.org)

**THE REPUBLIC OF TURKEY**  
**MINISTRY OF HEALTH**  
**TURKISH MEDICINES AND MEDICAL DEVICES AGENCY**

Certificate No: 203557 Date of Issue: 13 June 2022

**CERTIFICATE OF FREE SALE**

To whom it may concern,

It is hereby certified that the products detailed in the attached schedule, which are manufactured by "VITROSENS BİYOTEKNOLOJİ LTD. ŞTİ." (Şerifali Mah. Şehit Sk. No:17/1 ÜMRANIYE İSTANBUL), have been affixed with the CE mark in accordance with Medical Device Directives of the European Union (EU) and are freely sold in Turkey and EU.

This certificate is issued to be given to the relevant competent authorities of other countries and is valid for 36 months from the date of issue.

Yours sincerely,

**Omer Faruk KURU**  
Head of Medical Devices  
Registration and Coordination Department

This certificate consists of 7 page/s and 107 products. The products listed in the attached schedule are registered from the date of issuance of this certificate and information about the current status of these products is accessible through <https://utsuygulama.saglik.gov.tr/UTS/vatandas#yatTibbiCihazListele>

**UTS** ÜRÜN TAKİP SİSTEMİ

Address: Söğütözü Mahallesi, 2176. Sokak No:5 06520 Çankaya/ANKARA  
Phone: +90 312 218 30 00 Fax: +90 312 218 34 60 <https://www.titck.gov.tr>

**REPUBLIC OF POLAND**

## CERTIFICATE

**EC Certificate No. 1434-IVDD-252/2022**  
**EC Design-examination**  
**Directive 98/79/EC concerning**  
**in vitro diagnostic medical devices**

Polish Centre for Testing and Certification certifies that manufactured by:

**Vitrosens Biyoteknoloji LTD. Şti**  
**Serifali Mah. Şehit Sok. No: 17 34775 Istanbul,**  
**Turkey.**

in vitro diagnostic medical devices  
for self-testing

**RapidFor™ SARS-CoV-2 Rapid Antigen Test Kit (Nasal)**  
**1 Test/Box – REF. VSCD02ST01**  
**2 Tests/Box – REF. VSCD02ST02**  
**5 Tests/Box – REF. VSCD02ST05**

in terms of design documentation, comply with requirements of Annex III (Section 6) to Directive 98/79/EC (as amended) implemented into Polish Law, as evidenced by the audit conducted by the PCBC  
Validity of the Certificate: from 25.05.2022 to 27.05.2025  
The date of issue of the Certificate: 25.05.2022  
The date of the first issue of the Certificate: 25.05.2022

**CE** 1434

Issued under the Contract No. MD-203/2021  
Application No: 422/2021  
Certificate bears the qualified signature.  
Warsaw, 25/05/2022  
Module A1

**Director**  
Medical Device Certification  
Department

Elektroniczne podpisywanie  
przez Tomasa Anke Kowalek  
Data: 2022.05.25 12:30:39  
440507

**POLISH CENTRE FOR TESTING AND CERTIFICATION** 02-844 Warsaw, 469 Puławska Street, tel. +48 22 46 45 200, e-mail: [pcbc@pcbc.gov.pl](mailto:pcbc@pcbc.gov.pl)



# VITROAPP

AI Powered Scan | Fast & Safe Diagnostics







VO.V002-27122022

[vitrosens.com](http://vitrosens.com)